

Maxilift 2.0

13 Person Square (1000kg)

(1600mm wide x 1400mm deep)

MRL Hydraulic

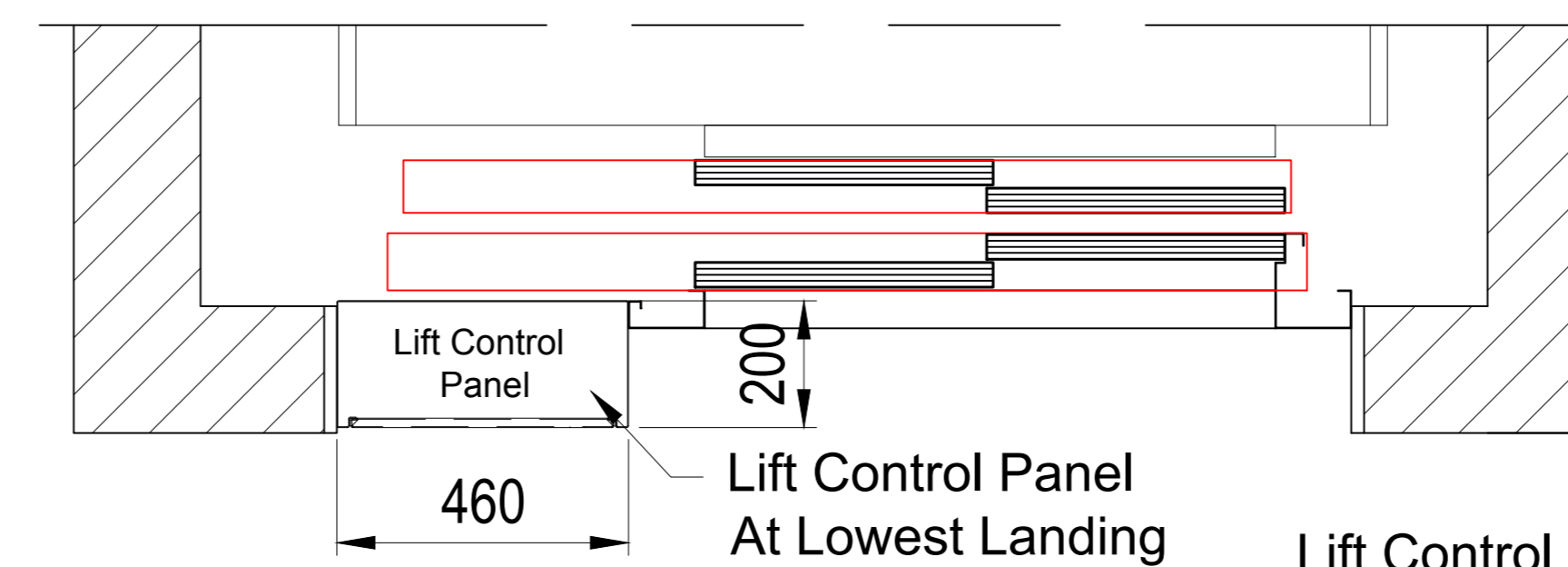
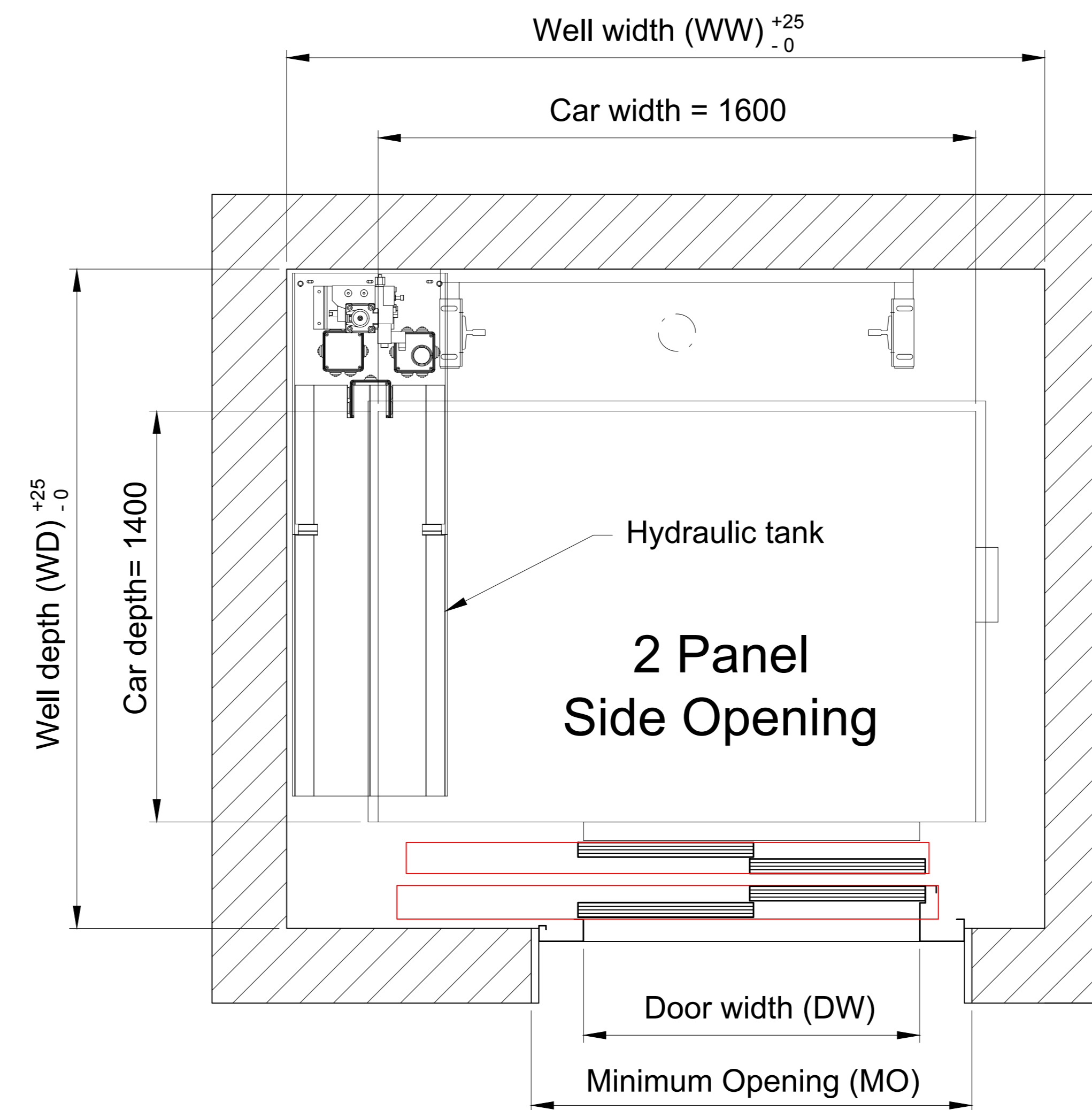
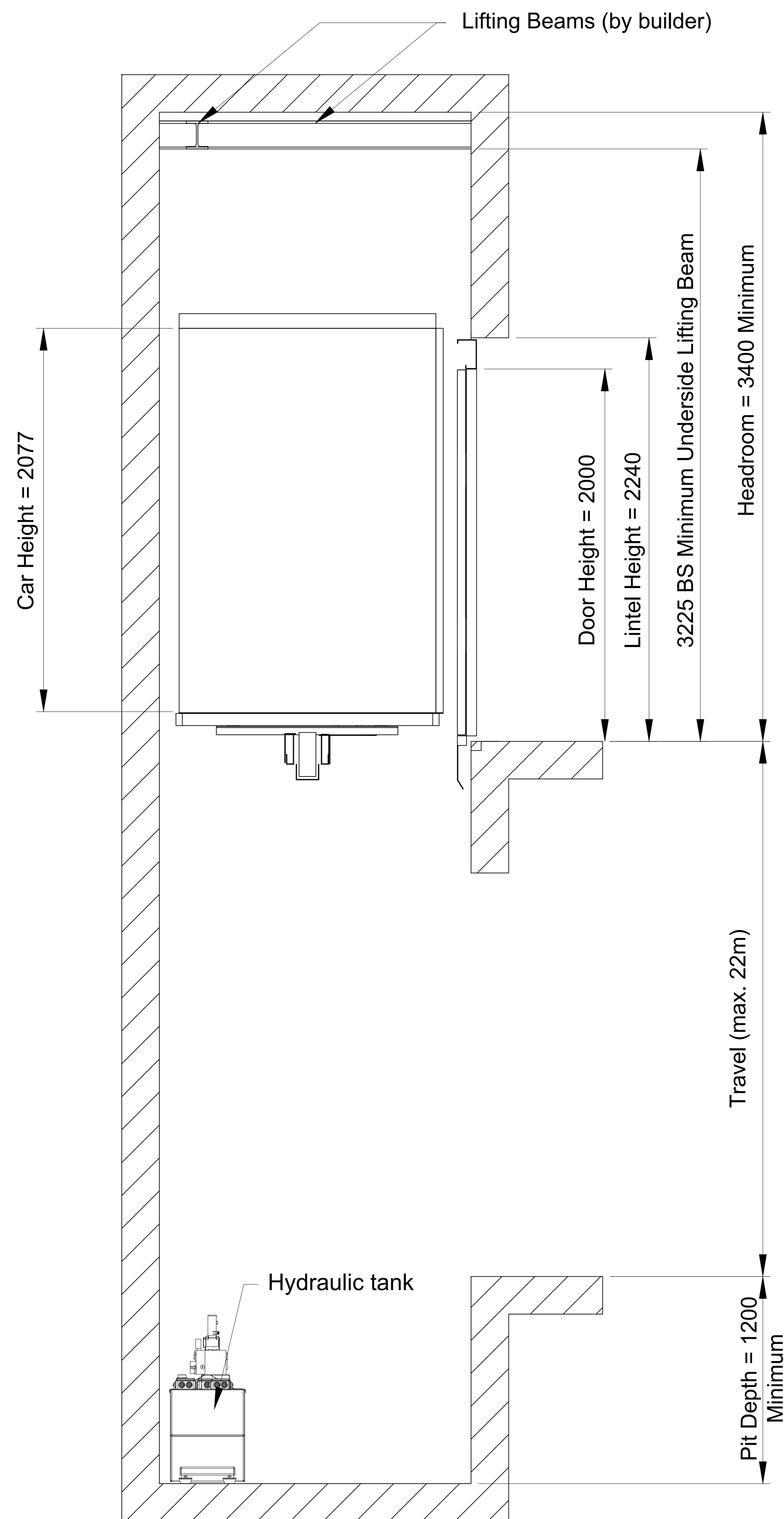

Lift Control Panel must be located at bottom floor only, next to the landing entrance

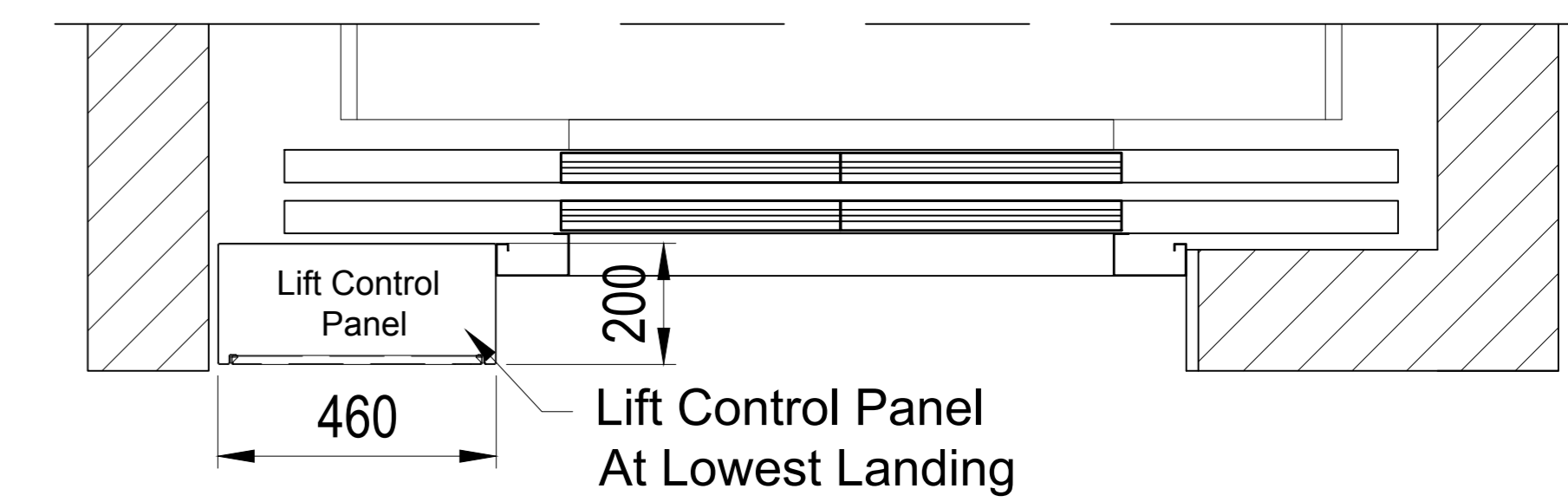
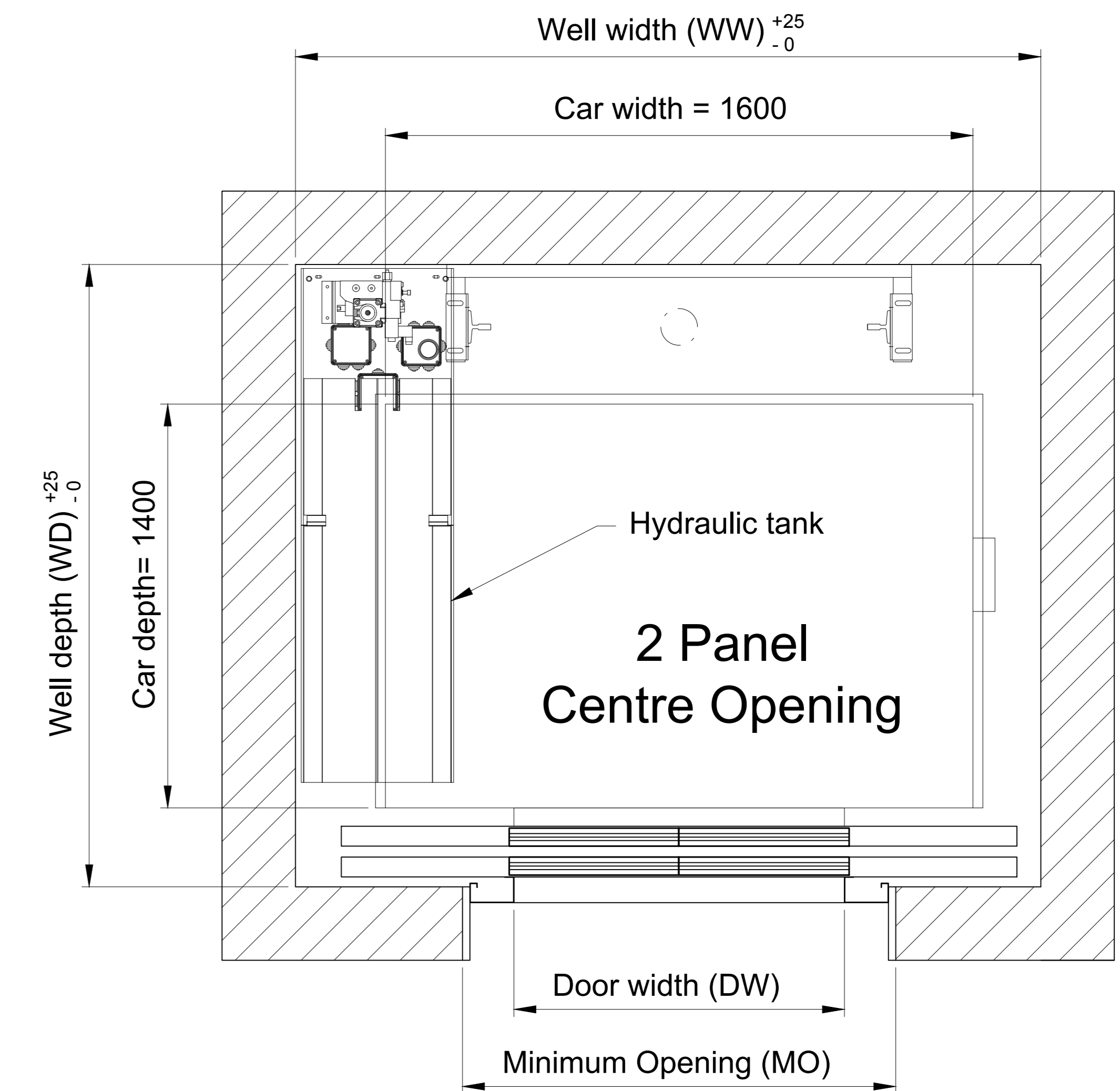

		Shaft Size		
		Single Entrance		
DW	Door type	WW	WD	MO
900	Side Opening	1970	2075	1200
	Centre Opening	2050	2035	
1100	Side Opening	1970	2075	1400
	Centre Opening	2400	2035	

Waiver:

This data sheet is for guidance only and must not be used for proper working drawings. Please contact Stannah Lifts for particular details before proceeding. Owing to our policy of continual improvement we reserve the right to alter specifications and dimensions without prior notice